



# Parents Almanac



**Public Affairs Office**  
**United States Military Academy**  
**West Point, New York 10996**  
Nineteenth Edition, May 2006



OFFICE OF THE SUPERINTENDENT  
UNITED STATES MILITARY ACADEMY  
WEST POINT, NEW YORK 10996-5000



Dear Parent:

Congratulations on your son's or daughter's acceptance to the United States Military Academy at West Point. The next four years will be an exciting and rewarding time for you as your cadet is educated and trained to become a leader of character for our Army.

*The Parents Almanac* contains information about West Point and the cadet experience. I trust it will help make you a better informed West Point parent. Keep in mind that information about cadet schedules and activities is general in nature and varies from year to year; it is always necessary to confirm specifics with your cadet before making plans.

West Point Parents Clubs offer an opportunity for mutual support and insight into the coming years. I urge you to join in the fellowship of a local club. A list of clubs is included in the almanac.

All at West Point look forward to welcoming you and your cadet on June 26.

Sincerely,

A handwritten signature in black ink, appearing to read "William J. Lennox, Jr.", written over a light blue background.

William J. Lennox, Jr.  
Lieutenant General, US Army  
Superintendent

# Cadet Life

## The West Point Experience



When cadets enter the academy, they become active duty members of the U.S. Army. They are taking the first steps toward joining the *Long Gray Line*, one of the proudest traditions in the Army and in the nation.

At the U.S. Military Academy, your cadet will be developed as a leader of character to serve our Army and country for a lifetime.

The demanding 47-month West Point experience transforms cadets into leaders. This experience includes academic, military and physical development. A strong emphasis on moral-ethical standards is woven into each developmental area.

You can be enormously proud of the accomplishments of your cadet. West Point is extremely selective, enrolling only the most promising young men and women. They are bright, eager and enthusiastic; and they demonstrate a high degree of extraordinary leadership potential. They are among the finest young people in America, and we are proud that they have chosen to come to West Point.

## Academic Program

During their first two years, the program of study consists of a core curriculum of science, English, mathematics, history, information technology and behavioral and social sciences. This broad base of knowledge forms the foundation for a higher level core curriculum, a minimum of three engineering courses, and specialization in an academic major.



Your cadets are responsible for keeping you informed about how they are doing. If they experience difficulty in a course, they should seek help immediately. Additional instruction (AI) is offered in every course. Cadets may also request a tutor through their company.

Academic requirements, coupled with the many other demands upon their time, place a great need for self-discipline on cadets. The Center For Enhanced Performance (CEP) offers a *Student Success Course* and *Critical Thinking and Information Literacy Course* through the Reading and Study Skills Program (RSSP). It also offers individual and team performance enhancement training through the Performance Enhancement Program (PEP) to help cadets adjust to academy life. Academy counseling is provided throughout a cadet's four years. Teams of faculty counselors assigned to each cadet company work with cadets during their first two years. In addition to

assisting with individual study challenges, the counselors help cadets clarify the areas of specialization in the curriculum best suited to their individual abilities and goals.

Early in their second year, departmental academic counselors assist cadets in selecting their major. The counselors are assigned to cadets according to the cadets' chosen major and provide counseling to the junior and senior classes. Individual course instructors are always willing to help cadets, and the academic counselors in the Dean's Office are available for academic guidance on a walk-in basis.

## Military Program



When new cadets arrive on R-Day, they begin to experience the military environment ever present at the academy. They are required to conduct themselves according to military standards. The first phase of military training is given during the six-week program known as Cadet Basic Training (CBT). CBT, or Beast Barracks, is one of the most strenuous and intense periods of training that cadets encounter while at the academy.

During CBT, upperclass cadets, tactical officers and noncommissioned officers (TAC Teams) train, inspire and mentor new cadets in basic soldier skills and prepare them for acceptance into the Corps of Cadets. In addition, the program is designed to inspire each new cadet to internalize the ideals of West Point and the Army. Along with instruction in military subjects, new cadets participate in drills, marches and overnight field training.

CBT culminates in a week of training and living in a field environment and a march back to West Point. Once they enter the gate, new cadets, led by the USMA Band, are greeted by well-wishers lining the streets as they pass-in-review before the Superintendent and senior members of the staff. On August 12, 2006, at 10:00 a.m., the Class of 2010 will be accepted into the Corps and acknowledged as cadets in a brigade review on the Plain. Plebes will then be allowed walking privileges (page 14).



Throughout the academic year, cadets receive instruction in military subjects. Military Science instruction during their first academic year includes two courses: MS101 *Introduction to the Army* and MS103 *Introduction to Warfighting*. MS101 introduces cadets to the Army, its heritage and its organization. In this course, cadets learn the seven Army values, the identities and principles of Officership, and basic Army customs and traditions to properly prepare them to begin their study of Military Science. MS103 is designed to provide cadets a foundation of tactical knowledge necessary for success during Cadet Field Training (CFT). Tactical instruction includes map reading, Troop Leading Procedures and an introduction to military planning. Cadets are also

introduced to dismounted platoon operations, patrolling, organization of a light infantry squad/platoon, and the characteristics of organic weapons.

## Physical Program



The mission of the Department of Physical Education is to create a cadet centered educational environment that provides a militarily relevant and scientifically based physical development program, and instills a warrior ethos of physical and mental superiority. The Department of Physical Education develops this by engaging cadets in activities that promote and enhance the warrior ethos, physical fitness, psychomotor performance and a healthy lifestyle. The Physical Program helps them develop physical skills, self-confidence, respect for fair play and a commitment to maintain individual and unit physical fitness. The Physical Program includes physical education instruction, fitness assessment and the competitive sports program.

The Instructional Program is accomplished through enrollment in the Basic Instruction Program (BIP), Fitness Leader I and II and a variety of Lifetime Sport (LTS) courses. The BIP courses consist of Survival Swimming, Boxing (M), Fundamentals of Combatives (W), Military Movement, and Close Quarters Combat. The LTS program is designed to stimulate individual development through participation in a wide variety of physical activity classes including rock climbing, tennis, alpine skiing, cycling and scuba.

The Competitive Sports Program requires cadets to participate in either the intramural, competitive club team or intercollegiate programs. Participation in competitive sports contributes to the will-to-win and moral-ethical and leadership development of cadets. By providing an environment in which Army values are reinforced and the principles of fair play are promoted, cadets learn how to “win the right way” which transfers directly to their role as officers. Fair play initiatives focus on demonstrating respect for the rules as well as one’s opponent, coaches, officials and teammates.

The Fitness Assessment Program is designed to assess a cadet’s progress toward achieving a high level of motor and physical fitness. Cadets are required to take the Army Physical Fitness Test (APFT) each academic term and the Indoor Obstacle Course Test (IOCT) during Third, Second and First Class years. Fourth Class cadets are introduced to and evaluated on the IOCT as part of PE 117-Military Movement. These tests are designed to monitor progress toward Physical Program goals and to motivate cadets to achieve a high level of physical fitness. In addition to the annual APFTs and IOCT, the health-related components of fitness are assessed and embedded in the core curriculum in the Fitness Leader I and II courses.

The academic year Physical Program is complemented with an intense and progressive Summer Training Program. This program is designed to prepare cadets for the physical demands of cadet/military service life and the combat environment. Summer field training provides each cadet repeated opportunities to apply principles learned during the academic year’s physical education curriculum. Specifically, the summer training program integrates military and physical training. This integration provides a forum where cadets are taught to apply and model the knowledge, psychomotor skills, attitudes and behaviors that result in a sustained high level of physical fitness and enhanced combat readiness.

The Physical Program contributes to all these aspects of learning. Cadets are challenged to successfully accomplish physically demanding skills, to increase self-confidence, determination, the will-to-win and to think and act purposefully under physical and emotional stress.

## **Ethical Development**

### **Professional Military Ethic Education (PME)**

The purpose of Professional Military Ethic Education is to provide cadets instruction that reinforces current academy programs and assists in developing the self-concept of Officership and the ethos of the American Military Profession. The PME program of instruction attempts to put all lesson objectives into the context of real life situations. The goal is to show cadets how their education fits into the big picture, both in society as a whole and the Army. The curriculum is designed to reinforce education in three areas fundamentally important to developing leaders of character, Values Education, Officership and Leader Development.

### **The Honor Program**

*“Duty, Honor, Country. Those three hallowed words reverently dictate what you ought to be, what you can be, what you will be. They are your rallying point...”*

General Douglas MacArthur spoke these words to the Corps of Cadets, on May 12, 1962, in his farewell address to West Point. The Cadet Honor Program is essential to the character development of cadets throughout their 47-month experience. The Program’s foundation is the Cadet Honor Code which states “A cadet will not lie, cheat, steal or tolerate those who do.”

### **The Respect Program**

For generations, the U.S. Military Academy has advocated respect for others as an integral part of leadership and inherent to the ethos of the professional military officer. The ability to educate, train and inspire leaders of character is linked to the Academy’s commitment to insure a positive command climate, eliminate discrimination and foster an atmosphere in which cadets can learn and develop equally without prejudice. The intent of the program is to engender a professional attitude that encompasses every aspect of cadet life and that is essential for effective leadership in the Army.

The Army and the U.S. Military Academy will not tolerate violations of equal opportunity (prejudicial and discriminatory behavior or unfair treatment based on race, religion, national origin, color or gender.) Therefore, the main function of the Respect Program is to educate cadets on equal opportunity issues. The program strives to enhance cadets’ understanding of a commitment to the fundamental principle that each individual intrinsically has infinite dignity and worth.

*“He who feels the respect which is due to others cannot fail to inspire in them regard for himself, while he who feels, and hence manifests, disrespect toward others, especially his inferiors, cannot fail to inspire hatred against himself.”*

*Major General John M. Schofield*

# ORGANIZATION OF THE CORPS OF CADETS DURING THE ACADEMIC YEAR

## CADET FIRST CAPTAIN

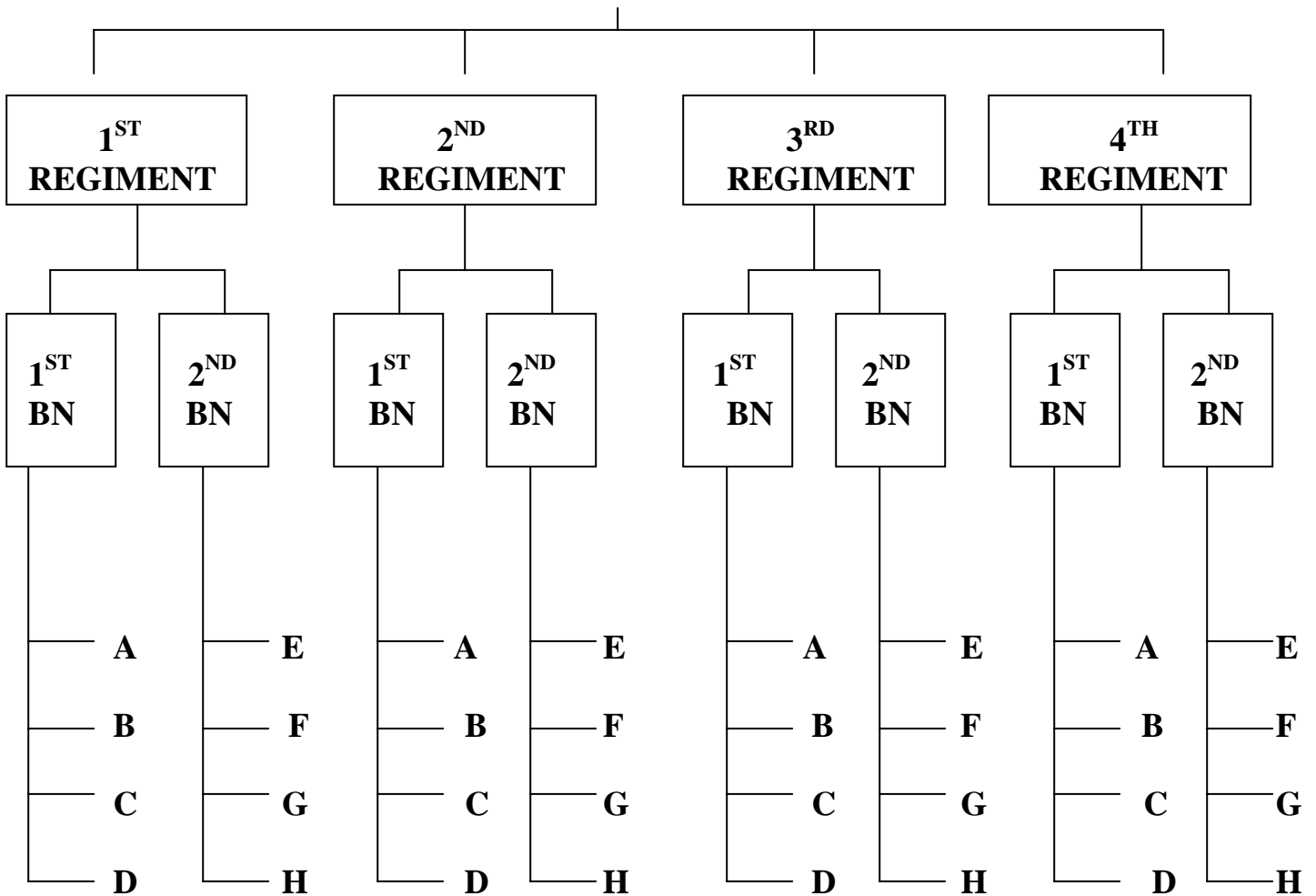

**BN = Battalion**

**Letters denote cadet companies**

### Cadet Company Orderly Room Telephone Numbers (845) 938-XXXX

A1-2663	A2-3570	A3-2962	A4-4125
B1-3238	B2-4431	B3-3236	B4-3343
C1-2897	C2-3761	C3-2664	C4-4120
D1-3033	D2-3293	D3-2763	D4-3370
E1-2391	E2-3195	E3-2466	E4-3364
F1-2944	F2-3556	F3-5476	F4-3776
G1-4330	G2-2983	G3-3085	G4-2444
H1-3260	H2-3285	H3-3189	H4-4346

## Cadet Rules and Regulations

### A, B and F Saturdays

A, B and F Saturdays refer to three kinds of Saturdays in the cadet academic year schedule. The following explanation is from an academy regulation:

**Alpha (A) Saturdays** are those Saturdays during which all cadets, except those participating in Corps Squad competitions and approved club or academic trip sections at or away from West Point are required to be in attendance for events scheduled on Saturday morning by the Commandant (A/C Saturday) or the Dean (A/D Saturday). Operating rules for A/D/ weekends include a formal evening study period (ESP) on Friday evening and Dean's activities on Saturday from 7:35 a.m. until 11:45 a.m. Operating hours for A/C weekends are the same as A/D weekends, to include the ESP on Friday evenings and 7:35 a.m. until 11:45 a.m. for Commandant's activities.

**Bravo (B) Saturdays** are those Saturdays during which all events for cadets are discretionary. Extracurricular activities will schedule their away events on Bravo Saturday weekends.

**Foxtrot (F) Saturdays** are those Saturdays during which the only requirements for cadets are in support of the home football game and supporting activities (i.e. guards, parade, march-on and Black Knight Alley). The Corps is required to attend each home game in support of the Army football team. The Commandant and the Dean will schedule no mandatory requirements for any cadets on a Foxtrot Saturday. Operating rules for F weekends include an Evening Study Period on Friday night.

Cadets will receive the specific schedule of Saturdays at the start of the academic year. Many parents who plan a trip to West Point often schedule it on a B Saturday weekend, which may allow them more time with their cadet. **Reminder: All information provided in this almanac is subject to an individual cadet's circumstances, eligibility criteria and duty requirements.**

### Leaves and Passes

Information about leaves and passes is contained in the USCC Standing Operating Procedures (SOP) and associated privilege memorandums for leave periods. Cadets are responsible for submitting all requests and obtaining approval for leaves or passes. Approval must be obtained from the cadet's Tactical Officer before making any travel arrangements.

A **Pass** is a privilege that may be earned. It is approved or disapproved by the company tactical officer (TAC). Plebes are eligible for one baseline pass during their first year.

Generally, all cadets are authorized **leave** as a part of the curriculum and as a respite from academic and military duties. Unless otherwise notified, cadets may take leave from West Point during Thanksgiving, December Winter Leave period, Spring Break and during the summer. Cadets will receive specific information through privilege memorandums at the start of the academic year that specifies departure and return times for these leave periods.

## Parents Club Almanac 2006

In the event of a family emergency, TACS may approve leave requests that meet the criteria for Army emergency leave status (death of a parent, “in loco parentis” or immediate family member). Passes may be granted for situations that do not meet the criteria for Army emergency leave by the Regimental Tactical Officer after approval from the TAC. Neither of these situations count against the cadet’s baseline passes for the semester. If parents cannot reach their cadet, they should call the cadet’s Tactical Officer or TAC NCO. Parents may also call the Central Guard Room (845-938-3030) which is staffed 24 hours a day or the Brigade Tactical Department Headquarters (845-938-6005).

### **Walking Privileges**

After Acceptance Day cadets in good standing have walking privileges for the weekend once they have completed all duties. On normal weekends, cadets may take walking privileges on Saturday after their last duty until 11 p.m. and Sunday from 7 a.m. to 7 p.m. There are additional allowances for holiday weekends specified in the USCC SOP.

As is the case in any explanation of cadet regulations, these are general guidelines that are subject to an individual cadet’s circumstances. It is the cadet’s responsibility to know the regulations and how to apply them to each particular case.

### **Parameters of Walking Privileges**

To the North: Washington Gate

To the East: The westerly bank of the Hudson River

To the West: The easterly side of Route 9W, with the exception that cadets traveling in a privately owned vehicle are permitted to ride down the westerly side of Route 9W to access an establishment on the easterly side of Route 9W

To the South: To the Bear Mountain Bridge Circle. Cadets traveling in a privately owned vehicle may travel to Bear Mountain State Park.

### **Historic Cadet Mess Hall in Washington Hall**



The neo-Gothic Cadet Mess Hall at West Point is an impressive structure configured like an enormous spoked wheel with six dining wings radiating from a central elevated “poop deck.” The Mess Hall seats and feeds the entire Corps of approximately 4,000 cadets in less than 25 minutes. It provides well-balanced nutritional meals that support the cadets very active daily life. To maintain the unity of the Corps, the use of the Mess Hall by others is highly regulated. Family members may eat in the Mess Hall with their cadet under the following guidelines:

**Official Guests:** Cadets of any class may invite and escort an official guest (official as deemed by Protocol or Public Affairs) or a member of the Armed Forces during any meal with minor exceptions listed in the USCC SOP.

## Parents Club Almanac 2006

**Unofficial Guest:** Cadets in their second through fourth year may invite and escort guests to informal meals only, with a maximum of five guests. The exception for first year cadets is during Plebe Parent Weekend when they may escort guests to informal meals. Other exceptions are listed in the USCC SOP.

- **Informal Meals:** Saturday lunch and dinner or Sunday brunch.
- **Official Weekends:** Special events are scheduled throughout the year for different classes. At such times guest meal tickets are not authorized.
- **Meal Hours:** Meal hours are posted on the cadet schedule and are strictly enforced.

### **Over the next four years cadets will have special event weekends to enjoy with their invited guests**

#### **Plebe-Parent Weekend Class of 2010, October, 13-16, 2006**

Plebe parents are invited to USMA to spend time with their cadets over this weekend to see what they have accomplished since their entrance into the academy. Other family members and friends are also welcome to visit at this time.

#### **Ring Weekend Class of 2007, August 25-27, 2006**

Firstie senior cadets receive their class rings in late August of their final year at the academy. This firstie occasion is celebrated with a weekend of events. There is a banquet and dance to top off the festivities on Saturday night.

#### **500th Night Weekend Class of 2008, January 19-21, 2007**

The date marking the 500th night before graduation prompts a January weekend of festivities for cows or juniors. This milestone in a cadet's schooling is typically celebrated with a Saturday night banquet, followed by a formal dance.

#### **Yearling Winter Weekend Class of 2009, February 2-4, 2007**

This weekend occasion is planned for yearlings or sophomores and their guests. Winter sports activities at West Point are highlighted, along with a Saturday evening banquet and formal dance.

#### **100th Night Weekend Class of 2007, February 23-25, 2007**

This late winter weekend marks the 100th night before graduation. It is a time of anticipation for these future officers and also an occasion for looking back at the humorous and unforgettable experiences they have shared during their time at West Point.

#### **Graduation Week**

Many special activities are planned during the week preceding the Saturday morning graduation ceremony. The USMA Operations Office sends firstie parents a Parents Guide for Graduation Week outlining the week's events. This is mailed in April of the cadet's senior year. Although some events begin as early as Wednesday, Friday is when the graduation parade, banquet and hop occur. Please remember: if you are planning to attend, you will need to make arrangements for lodging well in advance. Graduation Day for the Class of 2010 is May 29, 2010.

**Army Football Toll Free Number for Army Tickets 1-877-TIX-ARMY or purchase tickets on line at [www.goarmysports.com](http://www.goarmysports.com).**

## **Army Football**

**Choose from the following options to purchase tickets:**

### **Season Tickets**

(\$149 per season ticket)

### **Cadet Season Tickets**

A cadet may purchase season tickets for family and friends. That seating will be with other guests behind the Corps on the lower level. Each year, seating is reassigned based on each cadet's class year. Only cadets may purchase these tickets at the Army Ticket Office.

### **“A” Club Season Tickets**

Parents may wish to purchase their own season seats in different areas of Michie Stadium. All seating and parking assignments are based on donation level.

### **Single Game Tickets**

\$29 per ticket, except VMI-Homecoming and Air Force at \$36 per ticket

### **Cadet Single Game Tickets**

Cadets may purchase tickets for individual games at the Army Ticket Office. These seats are located in Sections 17A, 18 & 19 behind the Corps. Cadets may request a stub (no purchase necessary) to sit with their guests.

### **Other Single Game Tickets**

Parents, family and friends may purchase single game tickets for Army football. All seating is assigned based on level of giving to the Army “A” Club. Please contact the Army Ticket Office for special group rates and tailgating information.

### **Army-Navy Game**

The ticket prices for the 2006 Army/Navy game are as follows:

Lower and Upper Level \$52 per ticket; Club Level \$85 per ticket

The game is played at Lincoln Financial Field in Philadelphia, PA.

### **Cadet Seating**

Each cadet is entitled to purchase up to eight tickets to the Army-Navy Game in the cadet guest area. Seating is assigned by class year. These tickets can be purchased by cadets only and are subject to availability.

### **“A” Club Seating/Season Ticket Holder Seating**

By becoming an Army football season ticket holder, you may purchase as many Army-Navy tickets as you do season tickets. By joining the Army “A” Club (minimum annual contribution of \$50) you may purchase as many Army-Navy tickets as your level of giving permits. Seating for the Army-Navy game is assigned by donation level. Group purchases for individual parents clubs are only possible if the club makes an “A” Club contribution, or places orders as individual “A” Club donors along with a “sit together” request. All Army-Navy tickets are subject to availability.

### **R-Day Exception**

Plebe parents may purchase the cadet season, single & Army-Navy tickets on R-Day. After R-Day, cadet tickets may be purchased only by the cadet at the Army Ticket Office.



## 2006 Football Schedule

<b>DATE</b>	<b>OPPONENT</b>	<b>SITE</b>
Sept 2	at Arkansas State	Indian Stadium
<b>Sept 9</b>	<b>KENT STATE</b>	<b>MICHIE STADIUM</b>
Sept 16	at Texas A&M	Alamo Dome TX
Sept 23	at Baylor	Floyd Casey Stadium
<b>Sept 30</b>	<b>RICE</b>	<b>MICHIE STADIUM</b>
<b>Oct 7</b>	<b>VMI</b>	<b>MICHIE STADIUM</b>
Oct 14	at Connecticut	Rentschler Field
<b>Oct 21</b>	<b>TCU</b>	<b>MICHIE STADIUM</b>
Oct 28	at Tulane	Superdome
<b>Nov 3</b>	<b>AIR FORCE</b>	<b>MICHIE STADIUM</b>
Nov 18	at Notre Dame	Notre Dame Stadium
<b>Dec 2</b>	<b>NAVY</b>	<b>Lincoln Financial Field</b>

All home games are scheduled to be shown on ESPN/ESPN2 ESPN Classic or ESPNU. Check your local listings.

**Days/Times are subject to change**

Parents Club Almanac 2006

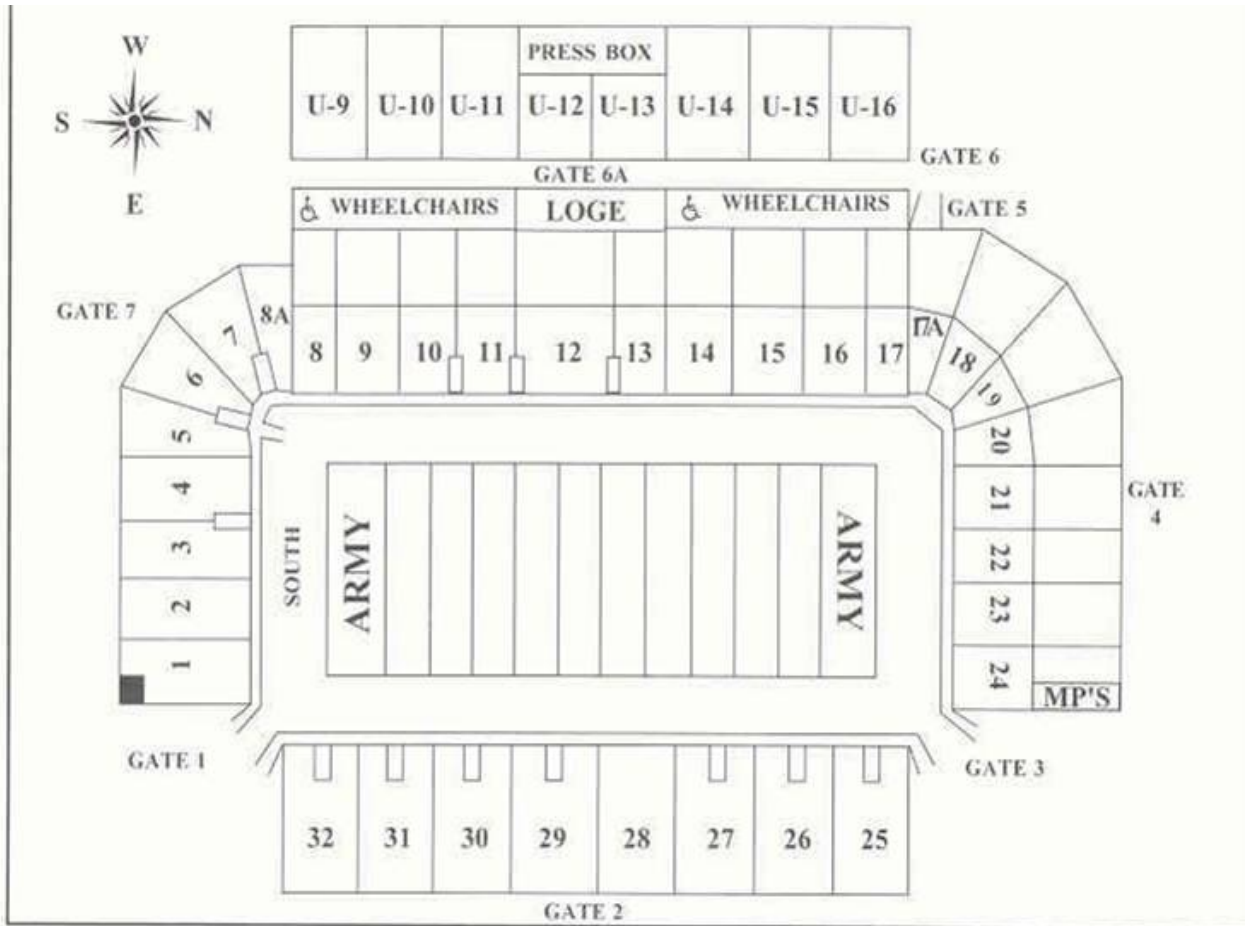

**FOR MORE INFORMATION**

**ARMY TICKET OFFICE**

Holleder Center  
 West Point, New York 10996  
 1-877-TIX-ARMY  
[www.goARMYsports.com](http://www.goARMYsports.com)

**ARMY 'A' CLUB**

639 Howard Road  
 West Point, New York 10996  
 845-938-2322 or 845-938-4444  
[ArmyAClub@usma.edu](mailto:ArmyAClub@usma.edu)

## **Reception Day (R-Day) June 26, 2006**

If it's feasible, attend Reception Day. It will help you to better understand the academy and what your new cadet will experience during CBT. Be sure to wear comfortable shoes and clothing. The weather can be hot, humid or rainy.

### **Activities/conveniences for parents:**

- Initial briefing and farewell (with your cadet)
- Shuttle bus service and guided bus tours around West Point
- Parents Reception Center
- Briefing held in Eisenhower Hall Theater by the Superintendent and Commandant
- New cadet Swearing-In Ceremony in the late afternoon by Trophy Point

### **Handy Items for Cadets to Bring:**

- Inexpensive watch
- Small overnight bag
- Stamped, pre-addressed envelopes to family and friends

## **Opportunities for parents and guests to visit West Point for the Class of 2010**

The class of 2010 will return to West Point on Monday, August 7, 2006, which is the conclusion of CBT. The Class of 2010 will pass in review in front of the Superintendent's Quarters at 9 a.m., on August 7, 2006. Parents and friends are welcome to come and cheer the Class of 2010 but will **NOT** have an opportunity to visit with their new cadet at this time. The new cadets will start Reorganization Week when they will move into barracks and pick up their books, uniforms, computers, phones, etc. for the start of the academic year on Monday, August 14, 2006.

An Acceptance Day Parade is held on Saturday, August 12, 2006, at 10 a.m. The Class of 2010 is welcomed into the Corps of Cadets as Plebes. The cadets normally enjoy walking privileges on Saturday after completion of their last duty usually early afternoon and again on Sunday. Cadets must return to their barracks each evening. If you plan on coming for the Acceptance Day Parade you should prearrange a meeting place with your cadet. Families can picnic at various locations around West Point. Barbeque sites are located at South Dock on a first come first served basis. Cadets normally have been allowed to visit Round Pond during the day over this weekend. If you want to make reservations please check their website at [www.usma.edu/mwr](http://www.usma.edu/mwr). In addition, some Parents Clubs may set up specific picnic areas for members, check with your local parent club.

## **Communicating with your Cadet**

### **Mail to Cadets**

Individual post office box numbers are sent to new cadets as part of a mailing from the Director of Admissions. The cadet's box number will remain the same for all 4 years at the Academy. New Cadet mailing addresses will also be available during R-Day at the Reception Center in Eisenhower Hall. Cadets can send their address within a day or two to parents who are unable to attend R-Day. Unless it's an emergency item (for example, eyeglasses), packages are not to be sent to new cadets during Cadet Basic Training.

Suggestions for parents:

- Bring a stamped envelope/card with you, place your cadet's new address on it, and drop it in the mailbox before leaving West Point. Your cadet will enjoy having mail right away.
- Write your cadet encouraging words as frequently as possible.
- Emphasize taking one day at a time and keeping a sense of humor.
- Send hometown news, cartoons, inspirational cards and a few pre-addressed and stamped post cards to your new cadet.

### **TAC Team**

The academy is often a cadet's first introduction to a military environment. TAC teams are instrumental in the cadet's transition to the military lifestyle. A Company TAC Team is composed of an active duty officer and senior non-commissioned officer (NCO). TACs are the program integrators of the Academy. They have the requisite military and civilian education and experiences to lead, coach and mentor cadets, ensuring an easy and thorough integration into the Corps of Cadets.

If you have any questions or concerns about any programs, events or your cadet, the TAC or TAC NCO should be your initial contact point. If you are unable to contact the TAC Team, you may call the Brigade Tactical Department at 845-938-6005.

### **E-mail and the Worldwide Web**

Cadets are prohibited from using the government computer network for profit-making activities. Cadets receive their personal laptops and printers during Reorganization Week. The simplest way to initiate an e-mail conversation is to have your cadet send an e-mail to your address. E-mail is not available for new cadets during CBT. The U.S. Military Academy has its own website on the worldwide web. The address is [www.usma.edu](http://www.usma.edu). This website offers invaluable information to parents. The Master Calendar is available on this site and will allow parents to check various dates such as Thanksgiving Leave, Winter Leave, Spring Leave and long weekends for cadets. To access the Master Calendar go to: [www.usma.edu](http://www.usma.edu). Click on search/reference then Master Calendar and it will list month by month activities happening at West Point.

## Parents Club Almanac 2006

### Packages and “Boodle Boxes”

“Boodle” is the cadets’ expression for goodies from home, and it’s a very effective morale-booster after CBT. **Do not send boodle during CBT.** When you send boodle, use an airtight container that will provide storage for future mailings. Boodle may be sent by the USPS directly to the cadet’s PO Box where your cadet can pick up the package or by commercial mail delivery services (UPS, FEDEX, etc.) All commercial mail delivery services must first go to the USMA Mail and Distribution Center to be scanned for security reasons. The Mail and Distribution Center normally will deliver packages to the Central Guard Room in the afternoon. If mail is received on a Friday afternoon, it will not be scanned or delivered to the Central Guard Room until the next work day. Commercial mail delivery services will not deliver to a PO Box number so the following address should be used:

Cadet John Smith, Company C4  
c/o Cadet Central Guard Room  
Building 745C  
West Point, New York 10997

(The zip code 10997 is used exclusively for mail delivered to USCC.)

The cadet-in-charge of quarters takes the package to the recipient’s company area, where it will be picked up by your cadet.

### Telephone Calls

Most new cadets will not be able to call home for 2-3 weeks after R-Day, although this changes from year to year. There are pay phones in all cadet barracks and new cadets will be allowed to use these phones to call home, time permitting. During Reorganization Week (Aug 7-14), all new cadets will be issued their personal phones.

### Cadet Home Address

If your address changes while your cadet is at the academy, he/she must go to the Cadet Personnel Office, S-1, to fill out a change of address form. **The cadet is the only person authorized to do this.**

If parents do not reside at the same location, remind your cadet to provide addresses for both parents. Each parent will then receive information sent out by the academy as authorized by the cadet.

## Medical Treatment

Cadets are active duty members of the U.S. Army and are entitled to complete military medical and dental benefits as long as they remain on active duty. Eligibility for military health benefits lasts until midnight of the date of discharge from active duty.

Retention of a civilian medical plan ensures continuous medical coverage after discharge. Please check with your plan's administrator about maintaining coverage for your cadet and before you try to use the private insurance to pay for care while the cadet is still active duty.

Cadets who are separated from the Academy because of an injury or illness suffered while on active duty may apply for medical care from the Department of Veteran Affairs. Cadets who resign for reasons other than injury or illness suffered while at the Academy are generally not eligible for VA medical benefits.

Cadets receive routine medical care at the Mologne Cadet Health Clinic and Keller Army Community Hospital or in the local TRICARE network. Don't panic if you hear your cadet is in the hospital. You may call the TAC Team at any time to get information. Cadets who have an illness that requires bed rest, such as the flu, are often hospitalized because they do not have the option of missing classes and resting in their rooms. Because of laws protecting the confidentiality of medical information, cadets are responsible for notifying their parents. If a serious injury occurs, the TAC officer will notify the parents. While in the hospital:

- Your cadet can call you by using a calling card or dialing collect.
- You can reach your cadet by calling the nurses' station at 845-938-3004/3045. Your call will be transferred to the cadet's room.
- Parents of cadets with significant illness or injury may speak with the cadet's attending physician. However, the physician cannot discuss medical information unless permission is granted by the cadet.

When a cadet is away from West Point on leave, pass or temporary duty (TDY), he or she is entitled to urgent care or emergency care only. Urgent medical care is treatment for an illness or injury that will not result in disability or death if not treated immediately, but should not be delayed until the cadet returns to West Point. Examples include sprains, ear aches, sore throats, rising temperatures. Authorization must be obtained before accessing urgent care. The cadet calls Health Net Federal Services at 877-874-2273 for authorization and assistance in locating suitable urgent care.

Emergency medical care does not require prior authorization. **An emergency is a sudden and unexpected illness or injury that threatens life, limb, or eyesight and/or a sudden, extremely painful condition that requires immediate treatment.** The cadet should go to the nearest military or civilian emergency room or call for an ambulance if needed. Cadets are required to carry a USMA Cadet Medical Benefits card that outlines procedures to be followed in an emergency and where to file medical claims.

Cadets receive routine dental care at the Saunders Dental Clinic at West Point. If emergency dental care is needed while away from West Point, the cadet must call the Military Medical Support Office at 888-647-6676 to find the nearest military dental facility or to obtain authorization for civilian dental care.

### **Counseling Support for Cadets**

Confidential counseling for cadets challenged by stress, adjustment issues, relationship concerns, sadness, diminished self-confidence, anger management problems, eating disorders and more is immediately available to all cadets. The **Center for Personal Development** (CPD) established in 1967 has four full-time licensed psychologists providing *confidential* support for cadets struggling with a wide variety of personal challenges including those who have been hurt in the past by child abuse and/or sexual assault. Appointments can be made on-line via the USCC Homepage where the counselors' biographies can also be found. Of the four counselors, three are active duty and one is civilian; two are male and two female. CPD is located in the cadet area in the 51<sup>st</sup> Div., Scott Barracks.

Despite the fact that the Corps of Cadets includes America's hardest young adults, they are not immune to stress and may at times feel isolated in their challenge. For these reasons the Academy wants to be sure cadets and their parents are aware of this supportive resource. If you sense your cadet may be confronted by an issue that is reducing his/her performance or exceeds his/her personal resources, encourage your cadet to schedule an appointment with one of CPD's counselors. If you have any questions or would like additional information about CPD you may call (845) 938-3327/3022.

### **Leave and Pass Transportation**

During major holiday and leave periods, USMA contracts bus transportation for cadets to various airports. Announcements about these buses are made in the Mess Hall and on the cadet computer bulletin board. Cadets need to buy bus tickets in advance

Cadets should allow themselves at least **three hours** for travel to LaGuardia, JFK, White Plains and Newark airports since traffic can cause significant delays. Travel from NY Hudson Valley International Airport, (formerly Stewart Airport) may be more convenient if flights go to your home area from there.

Cadets are encouraged to make their own arrangements. Parents **must** check with their cadet regarding leave dates before making reservations.

### **Getting the Word Out About Cadet Achievements**

The Academy's Public Affairs Office (PAO) sends Hometown News Release forms electronically to all new cadets at the completion of CBT, to all senior cadets just prior to graduation, to cadets earning academic achievement and to those who are appointed to chain of command positions. PAO can also prepare releases for other activities such as club sports and military training schools (e.g. airborne, air assault). However, these forms are not sent automatically and must be initiated by the cadet either by e-mail or in person to the PAO located in Taylor Hall (Building 600). PAO will send the completed releases directly to cadet parents to submit to their hometown papers. This system has proven to be very effective.

## Parents Club Almanac 2006

Another media opportunity offered to cadets and their parents occurs during Plebe-Parent Weekend. PAO sets up a Hometown News Release booth where photographs are taken of the Plebes with their visiting guests. Shortly after the visit, the photo and a suggested news release are sent to the parents, which they may then submit to their local newspapers. This service is provided free of charge.

Parents may also submit information about their cadet or USMA-related events that occur in their community directly to their local media.

Any questions about news releases can be directed to the Public Information Branch, Public Affairs Office or phone (845) 938-2006.

### Visiting West Point

#### General Suggestions

When visiting your plebe, plan on remaining on post or staying within the confines of their walking privileges. (Limits are explained in section, "Cadet Life.")

- Wear comfortable shoes.
- West Point has many picnic areas to enjoy.
- Home football game weekends are a lot of fun. The fall season is beautiful in the Hudson Valley. The games are exciting and tailgating at West Point is a unique experience.
- Visiting West Point when no special events are scheduled has the advantage of more free time with your cadets and fewer crowds.

#### Visitors Center

This facility, located outside of Thayer Gate in the Pershing Center, is open from 9 a.m. - 4:45 p.m. daily, except for New Year's Day, Thanksgiving Day and Christmas Day. Receptionists are available to provide information about West Point and the surrounding area.

Murals, videos, movies and other displays inform visitors of the mission, history and operation of the U.S. Military Academy. A commercial tour company operates from this facility, providing regularly scheduled bus tours that include points of interest like the Cadet Chapel and Trophy Point. Telephone: (845) 938-2638 or visit our website at [usma.edu/PublicAffairs/vic.htm](http://usma.edu/PublicAffairs/vic.htm) **The U.S. Military Academy is a Military Reservation and is under heightened security. When entering the Academy you will need to have a valid government issued photo ID for all adult members in the vehicle. All vehicles are subject to inspection. When making plans to visit the Academy be sure to allow extra time for possible delays at the gate.**

#### West Point Museum

The West Point Museum, the oldest museum in the Department of Defense, opened in 1854. It is located at Pershing Center behind the Visitors Center. It consists of six galleries which focus on

## Parents Club Almanac 2006

West Point and its history, the history of warfare, history of the U.S. Army in both war and peace, and a history of military small arms and large weapons. The collections are diverse and contain military arms, uniforms and flags, as well as military battle art, portraiture and other memorabilia related to West Point and the Corps of Cadets. The earliest exhibits date to 3000 B.C. with artifacts from Egypt's Old Kingdom, and the most current objects are from the Gulf War. Galleries are designed by theme and then chronologically to facilitate self-guided tours. For more information about the Museum, call (845) 938-3590/2203 or visit the museum's website at [www.usma.edu/Museum](http://www.usma.edu/Museum).

### **Constitution Island**

During the Revolutionary War, the fortifications at West Point and Constitution Island were critical to the defense of the Hudson River. The Constitution Island Association runs tours to Constitution Island for the public from June 25<sup>th</sup> until September 25<sup>th</sup> and at special times during the year. To reach the island, visitors take a ferry from the South Dock at West Point. Tours leave the South Dock at 1 p.m. and 2 p.m. on Wednesdays and Thursdays. Tours are approximately 2¼ hours in duration. Visit their website. [www.constitutionisland.org](http://www.constitutionisland.org) or call (845) 446-8676 to make reservations.

### **Gift Shops**

**West Point Gift Shop**, located in the same building as the Visitors Center, offers a full line of West Point-related clothing and souvenir items. The facility is open the same hours as the Visitors Center. Visit their website [www.goarmysports.collegesports.com](http://www.goarmysports.collegesports.com), or call (845) 446-3085/800-315-USMA.

**Daughters of the United States Army Gift Shops**, located in the museum and the lobby of the Thayer Hotel, have a variety of museum-related items, West Point souvenirs and other specialty products. Visit their website [www.dusagiftshop.com](http://www.dusagiftshop.com) or call the Museum at (845) 446-0566 or the Thayer Hotel Gift Shop at (845) 446-8681.

**Association of Graduates Gift Shop**, located in the James K. Herbert Alumni Center, offers a wide variety of fine West Point-related gift items, including china, crystal, pewter, prints and jewelry. Visit their website [www.westpointgiftstore.com](http://www.westpointgiftstore.com) or call (845) 446-3869.

### **Lodging - West Point Area**

For reservations at the Thayer Hotel (located at West Point) visit their website [www.thethayerhotel.com](http://www.thethayerhotel.com) or call 800-247-5047.

To stay at the Five Star Inn, visit their web-page at [www.usma.edu/mwr](http://www.usma.edu/mwr) or (845-446-5943/1028). Eligible patrons are active duty or retired military personnel, Air National Guard and Reserve personnel, family members of the above and DoD or retired civilian employees. Proper identification is required. Cadets can make reservations for parents to use the Five Star but must show their ID at the time of making the reservation. If cadets make reservations for family members for Acceptance Day they must go to the Five Star and show their ID prior to the date of arrival.

## Parents Club Almanac 2006

The following policy applies for making reservations at the Five Star:

Reservations may be made 30 days in advance. However, once a reservation is made, the arrival date may not be changed or cancelled. All guests will be charged from the original arrival date of their reservation. Rules for cadets using the Thayer Hotel and the Five Star Inn: Cadets of all ranks may use the lobby and public rest rooms. When invited, cadets of all ranks may visit the rooms of adult family members or adult family friends. Cadets are not authorized to rent rooms for their personal use or by their peers.

During Special event Weekends such as Home football games, Ring Weekend, Plebe Parent Weekend and Graduation non-military parents may make reservations at the Five Star 24 hours in advance.

### **The following organizations can provide information about hotels/motels in the West Point area:**

**The Chamber of Commerce of  
Orange County, Inc.,  
(845) 567-6229 or (Fax) (845) 567-6271**

**Orange County Tourism  
(845) 291-2136  
[www.orangetourism.org](http://www.orangetourism.org)**

**Westchester Convention & Visitors Bureau  
(800) 833-9282 or (914) 949-0047**

**Dutchess County Tourism Promotion Agency  
(800) 445-3131  
[www.dutchesstourism.com](http://www.dutchesstourism.com)**

**Putnam County Visitors Bureau  
Fax (845) 225-0381  
[www.visitputnam.org](http://www.visitputnam.org)**

**Rockland County  
(845) 708-7300  
[www.rockland.org](http://www.rockland.org)**

**The Town of Highlands  
[www.visiontownofhighlands.com](http://www.visiontownofhighlands.com)**

**Town of Highland Falls  
(845) 446-4280  
[www.highlandfallsny.com](http://www.highlandfallsny.com)**

**MAKE RESERVATIONS EARLY  
PARENTS CLUB MEMBERS ARE A GOOD SOURCE OF  
INFORMATION. CLUBS OFTEN RESERVE BLOCKS OF  
ROOMS FOR SPECIAL CADET EVENTS  
REMEMBER TO INQUIRE ABOUT THE HOTEL-MOTEL'S  
RESERVATION AND REFUND POLICY**

## Directions From Airports

The West Point area has five major airports—LaGuardia, JFK, Newark, Albany and Stewart International Airport (soon to be renamed NY Hudson Valley International Airport). NY Hudson Valley International Airport (Stewart Airport) is the closest to West Point. Newark and Albany are generally regarded as the next best choices. Driving directions from the airports are as follows:

**NY Hudson Valley Airport to West Point** [www.nyhvairport.com](http://www.nyhvairport.com). From the main entrance to NY Hudson Valley Airport turn left onto Route 207, which merges with Route 300. Remain on Route 300 until it intersects with Routes 32 and 94 at the Five Corners intersection in Vail's Gate. Continue on Route 32 to the second traffic light. Turn left toward Cornwall. Enter Route 9W South before entering Cornwall. Take 9W South to 2<sup>nd</sup> or 3<sup>rd</sup> West Point exit.

### **Newark to West Point** [www.panynj.gov/CommutingTravel/airports](http://www.panynj.gov/CommutingTravel/airports)

Take 95N/New Jersey Turnpike North to Exit 18. After final toll, continue on the expressway, but be on the lookout for a large sign for George Washington Bridge (about four miles after last toll). The highway will divide into Express and Local Lanes—stay in the Local Exit Lane (there will be three Local Lanes—try to stay in the far left lane). DO NOT take the George Washington Bridge exit. As you approach a large arch across the lanes, there will be a sign in far left Local Lane with Fort Lee and/or Palisades Parkway North directions—you will exit off left to a traffic light. Turn left at the light and go on the overpass. You will be in city traffic (stay in the right lane) and after three or so blocks, you will see a sign to exit right to the Palisades Interstate Parkway (PIP) North. Take PIP to the end (Bear Mountain traffic circle). Follow signs for Route 9W North (third exit off circle). Take the West Point/Highland Falls exit. Follow directions to Thayer Gate.

### **Albany to West Point** [www.albanyairport.com](http://www.albanyairport.com)

Go Southeast on Airport Access Road towards NY-155 East by turning to left. Turn slight left onto NY-155 East. Take I-87 South to I-90 East/I-87 South I-90 West exit number 1 towards Albany, Boston, New York, Buffalo. Keep right at the fork in the ramp. Merge onto I-87 South. Take the I-87 South exit, number 23 to 1 towards New York merge onto NY State Thruway toll road. NY State Thruway becomes I-87 South. Take NY State Thruway to exit 16 Harriman to Route 6 East to Route 293 South to Route 9W South. Take Route 9W South to signs for West Point.

### **From JFK or La Guardia** [www.panynj.gov/aviation/jfkframe](http://www.panynj.gov/aviation/jfkframe)

Follow signs to the Bronx Whitestone Bridge. After crossing the bridge, stay on the Hutchinson River Parkway North to Cross County Parkway West to 287 (NYS Thruway). Take the left lane exit to Tappan Zee Bridge and Interstate 87 (NYS Thruway). Over bridge, take exit 13 North onto the Palisades Interstate Parkway (PIP) heading North. Take the PIP to the end (Bear Mountain traffic circle). Follow signs for Route 9W North (third exit off circle). Take the West Point/Highland Falls exit. Follow directions to Thayer Gate.

### **White Plains Airport:** [www.westchestergov.com/Airport](http://www.westchestergov.com/Airport)

Take Route 684 South to Route 287 West, go over the Tappan Zee Bridge take Exit 13 North onto the Palisades Interstate Parkway (PIP) heading North. Take the PIP to the end, (Bear Mountain traffic circle). Follow signs for Route 9W North (third exit off circle). Take the West Point/Highland Falls exit. Follow signs to the Thayer Gate.

## **DIRECTIONS TO WEST POINT**

**From Westchester County and Southern Connecticut:** Take I-95 to Route 287 West, go over the Tappan Zee Bridge. Take exit 13 North onto Palisades Interstate Parkway (PIP) heading North follow signs to Bear Mountain/West Point. Take the PIP to the Bear Mountain traffic circle. Follow signs for Route 9W North/West Point (3<sup>rd</sup> exit off circle). Take the West Point/Highland Falls exit. Follow signs towards Thayer Gate.

**From Northern Westchester and Putnam Counties:** Take Route 9 to the Bear Mountain Bridge. Over the bridge, bear right and follow signs to Route 9W North (1<sup>st</sup> exit off bridge). Take the West Point/Highland Falls exit. Follow signs towards Thayer Gate.

**From Northern Connecticut:** Take 84 West over Newburgh/Beacon Bridge. Exit at 10S stay to right at traffic light turn right onto Route 9W South. Follow for approximately 15 miles to 2<sup>nd</sup> or 3<sup>rd</sup> West Point exit.

**From Northern New Jersey:** Take NYS Thruway North/1-87 to exit 16 Harriman to Route 6 East to Route 293 to Route 9W South. Take Route 9W South to 2<sup>nd</sup> or 3<sup>rd</sup> West Point/Highland Falls exit.

**From New York City:** Take the George Washington Bridge (upper deck) to the Palisades Parkway (PIP) North. Take the PIP to the Bear Mountain traffic circle. Follow signs for Route 9W North/West Point (3<sup>rd</sup> exit off circle). Take the West Point/Highland Falls exit. Follow signs towards Thayer Gate.

**From Albany:** Take the NYS Thruway South to exit 16. Pass through toll, take the first exit and turn left at light. Take Route 6 toward Bear Mountain Bridge. Stay straight on Route 6. Bear left onto Route 293 to Route 9W South. Take 9W South to 2<sup>nd</sup> or 3<sup>rd</sup> West Point/Highland Falls exit.

**From Boston/New England:** Take 90 West/Mass Pike to 84 West (Exit 9, Hartford/NYC). Once over the Newburgh/Beacon Bridge exit at 10S stay to right at traffic light turn right onto 9W south. Follow for approximately 15 miles to 2<sup>nd</sup> or 3<sup>rd</sup> West Point exit.

## Calendar of Events for 2006-2007

June 26	“R” Day	December 10-17	Final Exams (TEES) after last class/duty
August 7	CBT March Back	December 16	Winter Break begins after last class/duty
August 12	Acceptance Day Parade	January 2	Winter Break ends
August 14	First Day of Classes	January 15	Martin Luther King (no classes)
September 4	Labor Day (no classes)	February 16	Presidents Weekend (no classes)
October 13-16	Plebe Parent Weekend	February 19	Presidents Weekend (no classes)
November 10	Veterans Day (no classes)	March 10-18	Spring Leave
November 22	Thanksgiving Leave cadets will leave after last duty/class	May 14	Final Exams TEES
December 2	Army/Navy	May 26	Graduation '07

### Useful Numbers

**Note: The area code for the following numbers is 845**

Admissions Office	938-4041	Thayer Hotel Reservations	446-4731
Athletic Ticket Office	446-4996	Information Operator	938-4034
Brigade Tactical Dept.	938-6004	Jewish Chapel	938-2766
Bus Transportation	938-2018/2047	Keller Army Hospital Info	938-5169
Cadet Bookstore	938-5356	Museum	938-2203
Cadet Chapel	938-2308	Old Cadet Chapel	938-4106
Cadet Counseling Center	938-3022	Parents Club Coordinator	938-5650
Catholic Chapel	938-8760	Sports Scores	938-ARMY
Credit Union	446-4946	Visitors Center	938-2638
Ike Hall Box Office	938-4159	Central Guard Room	938-3030

Parents Club Almanac 2006

**REGIMENTAL TACTICAL ROSTER**

As of 20 January 2006

**HQ (MACC-O)**

Brigade Tactical Officer	x6005
Secretary	x6004
Brigade Executive Officer/Regs & Discipline Officer	x4029

**1<sup>ST</sup> REGIMENT (M/ACC-O-1) (Class 2006)**

Regimental Tactical Officer	x2901
Executive Officer	x2904

**TACTICAL OFFICERS AND NCO'S**

A1 Tactical Officer	x2613
Non-Commissioned Officer	x3190
B1 Tactical Officer	x2905
Non-Commissioned Officer	x5004
C1 Tactical Officer	x3803
Non-Commissioned Officer	x2125
D1 Tactical Officer	x3603
Non-Commissioned Officer	x4555
E1 Tactical Officer	x2903
Non-Commissioned Officer	x2102
F1 Tactical Officer	x3307
Non-Commissioned Officer	x2551
G1 Tactical Officer	x2408
Non-Commissioned Officer	x4853
H1 Tactical Officer	x2427
Non-Commissioned Officer	x2195
Chaplain	x2784

**3<sup>RD</sup> REGIMENT (MACC-O-3) (Class 2007)**

Regimental Tactical Officer	x4402
Executive Officer	x4405

**TACTICAL OFFICERS AND NCO'S**

A3 Tactical Officer	x3501
Non-Commissioned Officer	x3935
B3 Tactical Officer	x3302
Non-Commissioned Officer	x2823
C3 Tactical Officer	x2101
Non-Commissioned Officer	x2694
D3 Tactical Officer	x2619
Non-Commissioned Officer	x3289
E3 Tactical Officer	x4877
Non-Commissioned Officer	x4116
F3 Tactical Officer	x2902
Non-Commissioned Officer	x2089
G3 Tactical Officer	x2827
Non-Commissioned Officer	x4393
H3 Tactical Officer	x2921
Non-Commissioned Officer	x5993
Chaplain	x3412

**2<sup>ND</sup> REGIMENT (MACC-O-2) (Class 2005)**

Regimental Tactical Officer	x3706
Executive Officer	x2623

**TACTICAL OFFICERS AND NCO'S**

A2 Tactical Officer	x2725
Non-Commissioned Officer	x4830
B2 Tactical Officer	x4119
Non-Commissioned Officer	x3750
C2 Tactical Officer	x2622
Non-Commissioned Officer	x3043
D2 Tactical Officer	x3643
Non-Commissioned Officer	x5444
E2 Tactical Officer	x2824
Non-Commissioned Officer	x2421
F2 Tactical Officer	x3108
Non-Commissioned Officer	x3962
G2 Tactical Officer	x2528
Non-Commissioned Officer	x2196
H2 Tactical Officer	x2620
Non-Commissioned Officer	x3557
Chaplain	x3412

**4<sup>TH</sup> REGIMENT (MACC-O-4) (Class 2008)**

Regimental Tactical Officer	x2028
Executive Officer	x2825

**TACTICAL OFFICERS AND NCO'S**

A4 Tactical Officer	x3118
Non-Commissioned Officer	x5265
B4 Tactical Officer	x2922
Non-Commissioned Officer	x2468
C4 Tactical Officer	x3719
Non-Commissioned Officer	x3089
D4 Tactical Officer	x3718
Non-Commissioned Officer	x3034
E4 Tactical Officer	x2009
Non-Commissioned Officer	x2770
F4 Tactical Officer	x2727
Non-Commissioned Officer	x3853
G4 Tactical Officer	x2602
Non-Commissioned Officer	x5252
H4 Tactical Officer	x2627
Non-Commissioned Officer	x3577
Chaplain	x2784

*“It’s all about leadership”*

